

Strata Annex 860

Product Code: WAS860

Features



- IP47 for installation flexibility
- Dual wired (left or right)
- 12 Volt
- Quality stainless steel
- Installation requires access to wall cavity for easier installation.

Technical Details

Width 860mm, Depth 70mm, Height 50mm,

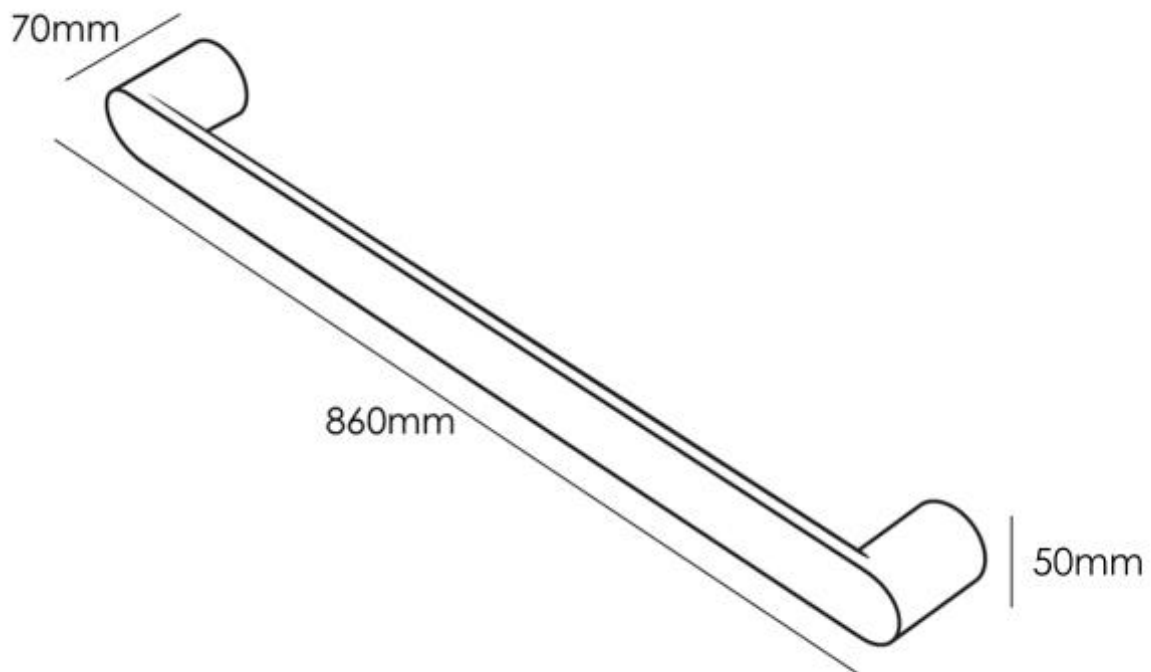

Note: all specifications and dimensions are correct at time of publication however are subject to change without notice. Please refer to physical product prior to installation.