

Storm Shower Mixer with Diverter



PRODUCT CODE

VST35BG

COLOUR/FINISHES

Brushed Gunmetal (PVD)

Chrome

Brushed Copper (PVD)

Brushed Nickel (PVD)

Brushed Brass (PVD)

FACEPLATE DIAMETER

80mm

PRESSURE TYPE

Mains Pressure only

MAXIMUM PRESSURE

500kPa (As per NZ Building Code AS/NZ 3500.1)

MINIMUM PRESSURE

150kPa

MAXIMUM TEMPERATURE

65°C

PLUMBING CONNECTION

15mm

CERTIFICATION

WaterMark Certified

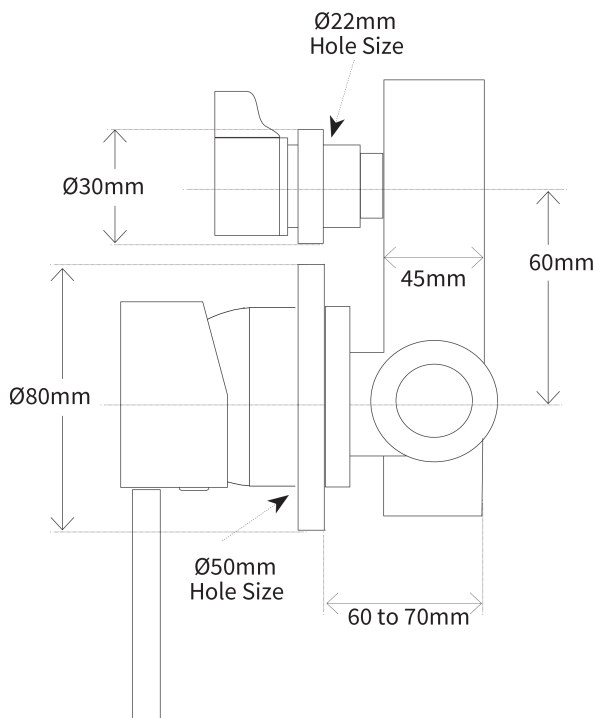

BUILDING CODE CLAUSES RELEVANT TO THIS PRODUCT:

Clause G12 Water Supplies, specifically G12.3.5, G12.3.6, and G12.3.7.

www.vodaplumbingware.co.nz/building-code-clauses/

This product is not subject to a warning or ban under section 26 of the Building Act 2004.

Specifications and dimensions correct at time of publication however are subject to change without notice.

Please refer to physical product prior to installation.

Installation instructions for this product are available from the product page on vodaplumbingware.co.nz