

# Wall Mounted Shower Drencher (Round)

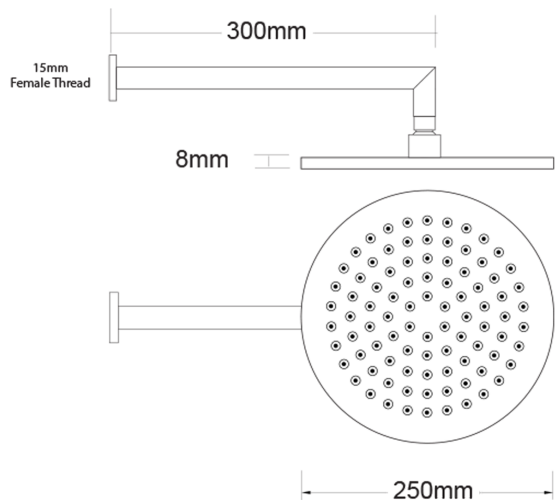

PRODUCT CODE

**NRT81RWCH**

COLOUR/FINISHES

Brushed Nickel (PVD)  
Brushed Brass (PVD)  
Brushed Gunmetal (PVD)  
Matte Black  
**Chrome**

PRESSURE TYPE

All Pressures

MIN. PRESSURE

35kPa

MAX. PRESSURE

500kPa (As per NZ Building Code AS/NZ 3500.1)

MAX. TEMPERATURE

65°C

PLUMBING CONNECTION

15mm

WELS RATING

Low/Unequal 2 Star; 10L/min  
Mains 3 Star; 6.5L/min

SHOWER HEAD SIZE

250 x 250mm

ARM LENGTH

300mm

Specifications and dimensions are subject to change without notice.

Installation instructions are available from the product page on [www.foreno.co.nz](http://www.foreno.co.nz)

BUILDING CODE CLAUSES RELEVANT TO THIS PRODUCT:  
Clause G12 Water Supplies, specifically G12.3.5, G12.3.6, and G12.3.7. [www.foreno.co.nz/building-code-clauses/](http://www.foreno.co.nz/building-code-clauses/)

This product is not subject to a warning or ban under section 26 of the Building Act 2004.