

# NORTH Wall Mounted Basin Mixer

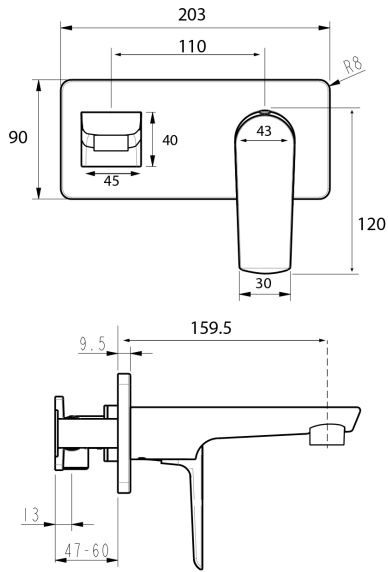

PRODUCT CODE

**NRT21CH**

COLOUR/FINISHES

Brushed Brass (PVD)  
Brushed Gunmetal (PVD)  
Matte Black  
**Chrome**

PRESSURE TYPE

All Pressures

MIN. PRESSURE

35kPa

MAX. PRESSURE

500kPa (As per NZ Building Code AS/NZ 3500.1)

WELS RATING

Low/Unequal 4 Star; 7L/min  
Mains 4 Star; 6.5L/min

MAX. TEMPERATURE

65°C

PLUMBING CONNECTION

15mm

SPOUT REACH

159.5mm

FACEPLATE (W X H)

203 x 90mm

BUILDING CODE CLAUSES  
RELEVANT TO THIS PRODUCT

CLAUSE G12 WATER SUPPLIES,  
SPECIFICALLY G12.3.5, G12.3.6, AND  
G12.3.7

Specifications and dimensions are subject to change without notice.

Installation instructions are available from the product page on [www.foreno.co.nz](http://www.foreno.co.nz)

BUILDING CODE CLAUSES RELEVANT TO THIS PRODUCT: Clause G12 Water Supplies, specifically G12.3.5, G12.3.6, and G12.3.7. [www.foreno.co.nz/building-code-clauses/](http://www.foreno.co.nz/building-code-clauses/)

This product is not subject to a warning or ban under section 26 of the Building Act 2004.