

EQUALISER Sink Mixer

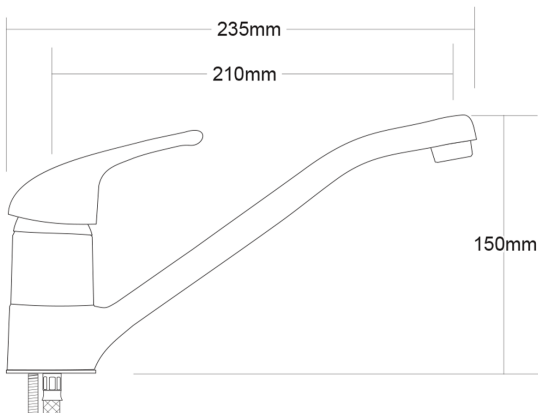

PRODUCT CODE

EQMX1.1

COLOUR/FINISHES

Chrome

PRESSURE TYPE

All Pressures

MIN. PRESSURE

17kPa

MAX. PRESSURE

500kPa (As per NZ Building Code AS/NZ 3500.1)

WELS RATING

Low/Unequal 2 Star; 10.5L/min
Mains 4 Star; 6.5L/min

MAX. TEMPERATURE

65°C

PLUMBING CONNECTION

15mm

CARTRIDGE TYPE

FORPT158 – HiFlo 40mm Cartridge

REPLACEMENT PART/S

Handle – FORPT21
Spout Bucket Washers – FORPT191

Specifications and dimensions are subject to change without notice.

Installation instructions are available from the product page on www.foreno.co.nz

BUILDING CODE CLAUSES RELEVANT TO THIS PRODUCT:
Clause G12 Water Supplies, specifically G12.3.5, G12.3.6, and G12.3.7. www.foreno.co.nz/building-code-clauses/

This product is not subject to a warning or ban under section 26 of the Building Act 2004.