

EQUALISER Basin Mixer

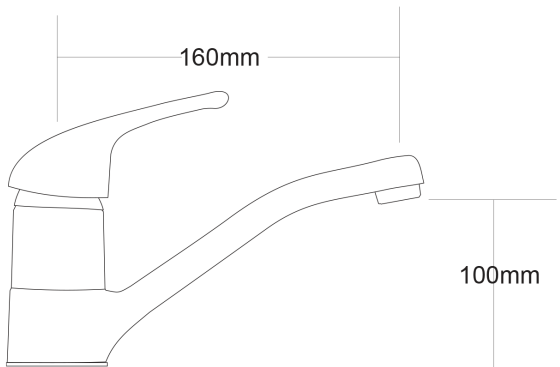

PRODUCT CODE

EQMB3

COLOUR/FINISHES

Chrome

PRESSURE TYPE

All Pressures

MIN. PRESSURE

17kPa

MAX. PRESSURE

500kPa (As per NZ Building Code AS/NZ 3500.1)

WELS RATING

Mains 4 Star; 6.5L/min
Low/Unequal 2 Star; 10.5L/min

MAX. TEMPERATURE

65°C

PLUMBING CONNECTION

15mm

REPLACEMENT PART/S

Handle – FORPT21

CARTRIDGE TYPE

FORPT127 – 40mm Cartridge with
Distributor

Specifications and dimensions are subject to change without notice.

Installation instructions are available from the product page on www.foreno.co.nz

BUILDING CODE CLAUSES RELEVANT TO THIS PRODUCT:
Clause G12 Water Supplies, specifically G12.3.5, G12.3.6, and G12.3.7. www.foreno.co.nz/building-code-clauses/

This product is not subject to a warning or ban under section 26 of the Building Act 2004.