

Code Form Vanity – 2 Drawer Open Shelf Double Basin - 1500

Product Code: F-150-MB, F-150-MW



Features

- 100% Waterproof
- 10 Year warranty
- German Hettich Runners
- NZ Designed
- Coloured Inlay handles available
- Made to be predrilled onsite (Tap and waste holes can be easily drilled.)
- Features optional coloured inlay handles
- Material: Recyclable WPC (Wood Plastic Composite board)

Technical Details

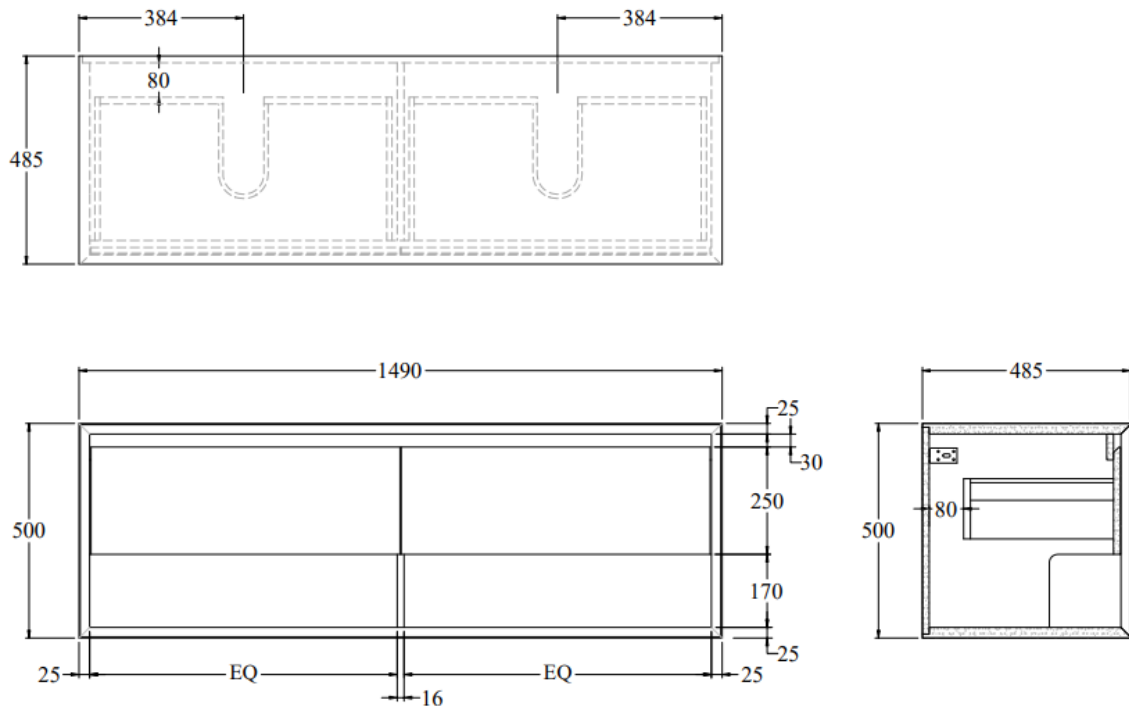

Note: all specifications and dimensions are correct at time of publication however are subject to change without notice. Please refer to physical product prior to installation.