

# SPECIFICATION SHEET

## Broadway 900mm Mirror

Newtech Code: 8870

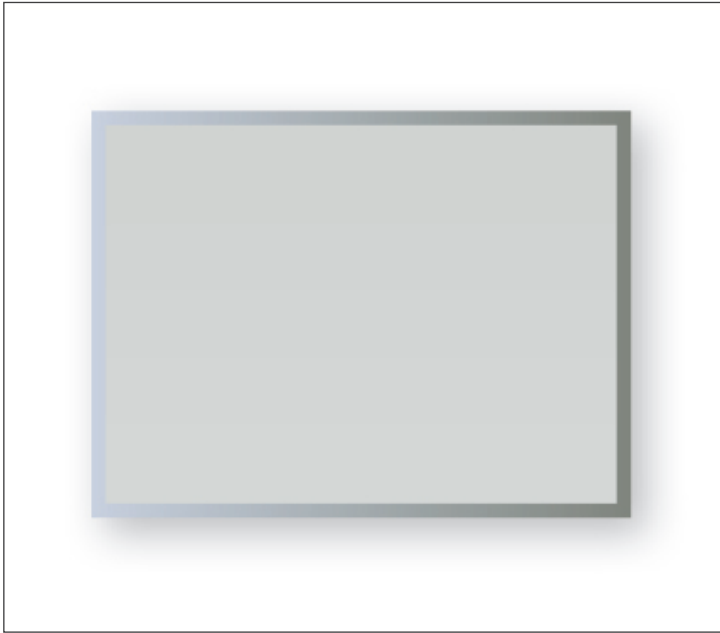

### Features

- LED Lighting with Touchless Sensor Switch
- Demister size is 310x450
- Dimensions: H700 x W900 x D43
- LED Watts: 22W
- LED Modules: 363 LED Modules
- Equivalent to: 120W/Incandescent  
Lumens: 1850
- 5mm Mirror Glass

### Specification / Compliance

- Safety Film Vinyl Backing
- Plexi Glass Frame Enclosing LEDs
- IP44 Rating

### Technical Details

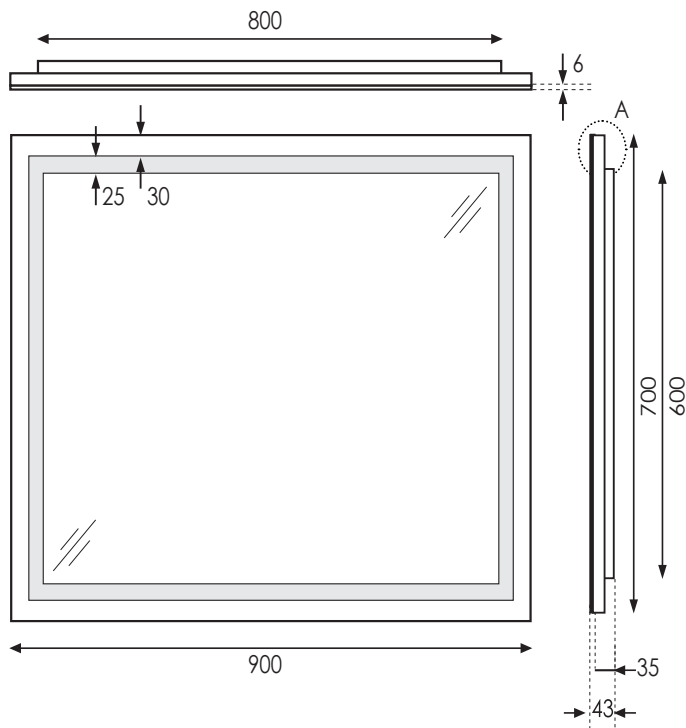

Note: This product must be installed with a minimum distance of 150mm between the infrared sensor and an adjacent countertop or obstruction to ensure correct function of the sensor. The IR sensor will not function correctly without this clearance.

