

# SPECIFICATION SHEET

## Avila 900mm 1 Drawer Wall Vanity



### Features

- Wall Hung
- Soft close full extension drawer
- Negative detail finger pull
- Water resistant materials
- Single Basin
- Colours: Timber Veneer on Plywood
- Dimensions: H415 x W900 x D465

### Colour Options with Code



Blanco Oak  
**8681BO**



Washed Oak  
**8681WO**



American  
Walnut  
**8681AW**

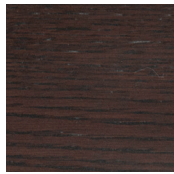

Dark Oak  
**8681DO**

### Technical Details

Note: All measurements shown are in millimetres. Sizes are nominal.

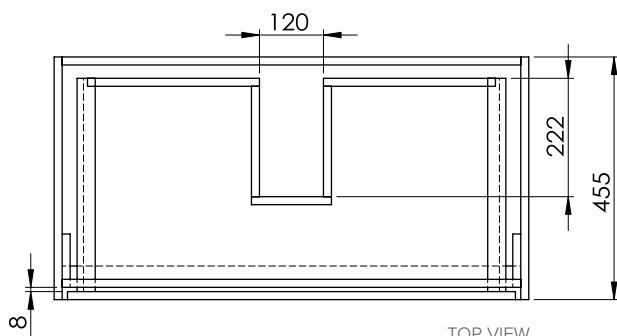

TOP VIEW

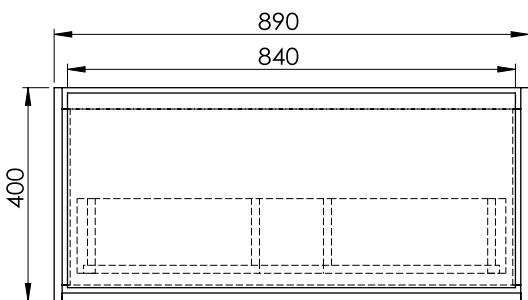
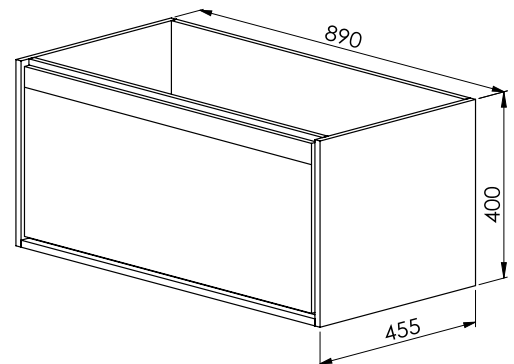

FRONT VIEW

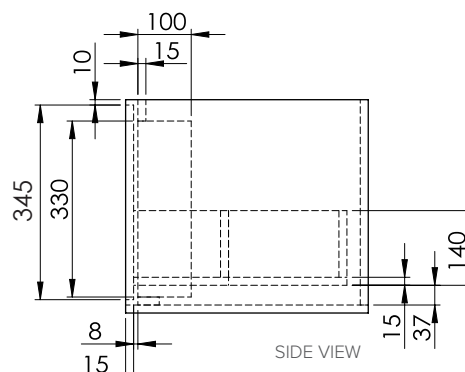

SIDE VIEW